

# MASTER MOTOR PARTS LIST

## TOP COVER, AIR FILTER & CARBURETTOR

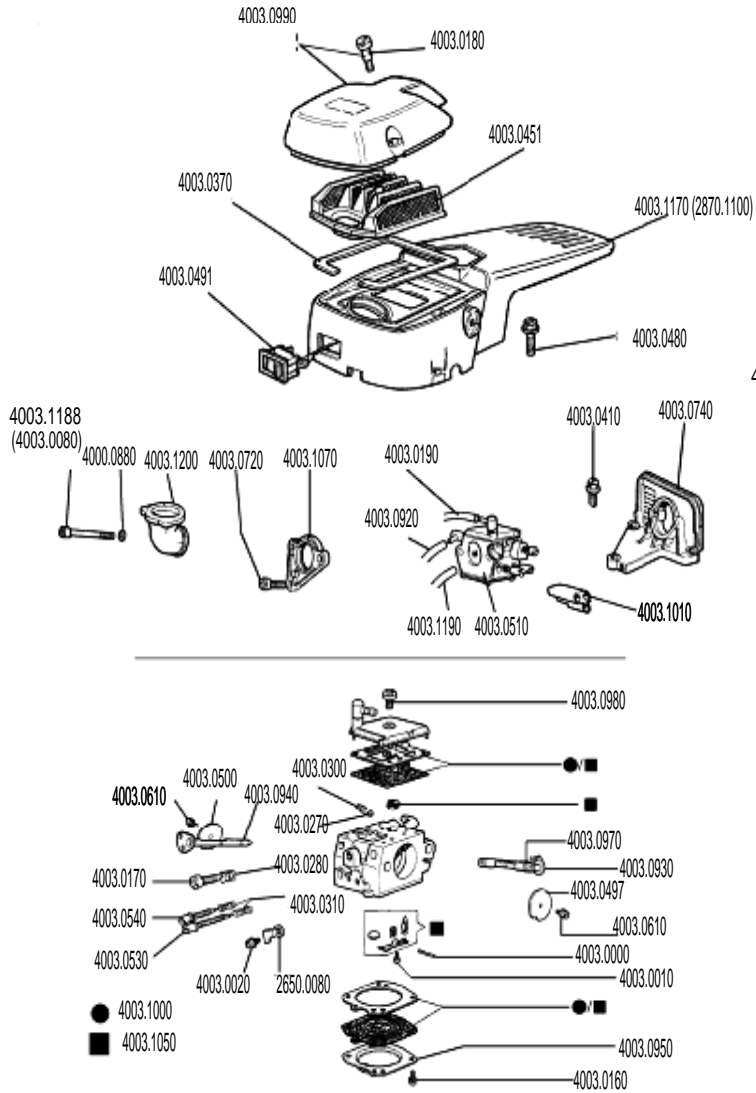

## STARTER ASSEMBLY

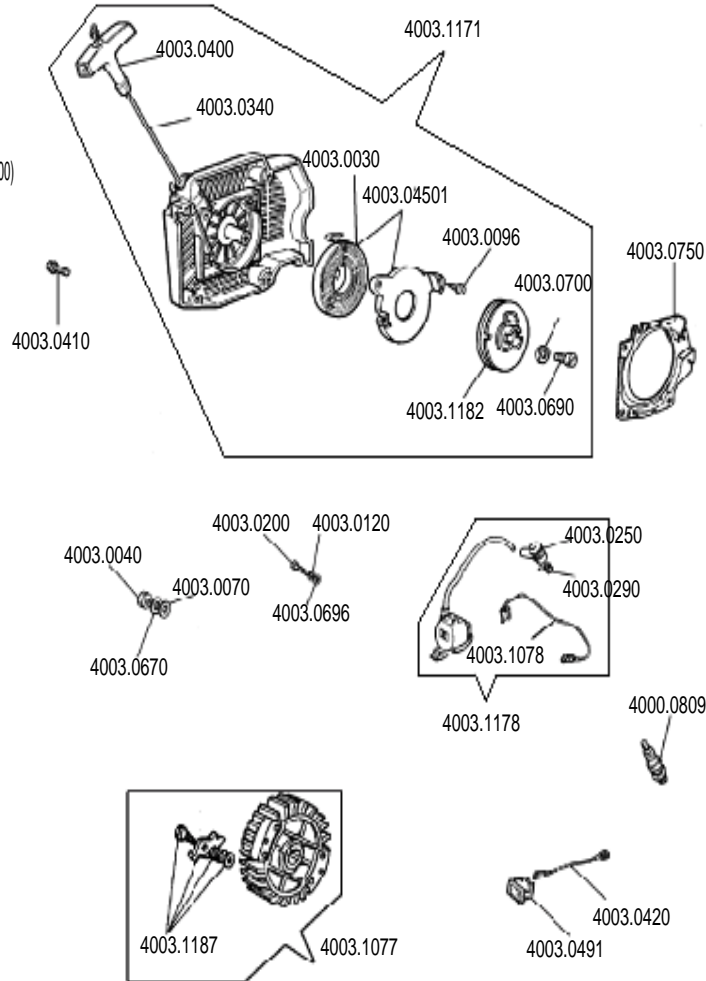

## CYLINDER & PISTON

